

LAPMASTER[®]

MODEL 20

PRECISION PNEUMATIC LIFT LAPPING MACHINE



- The Lapmaster model 20 (pneumatic lift) is a bench-mounted unit with a heavy duty, carbon steel weldment base. The machine is of the "ring lapper" or "planetary lapper" configuration, enabling high standards of flatness and surface finish to be routinely achieved.
- The model 20 is derived from the popular model 12 and 15 machines but features a steel weldment base instead of cast aluminium. A scaled-up lapping plate, conditioning rings and convenient "wrap-around" worktable combine to form a unique package. (The model 20 is the largest bench-mounted machine in the USA offered by any company.)
- The machine is equipped with a pneumatic system for prescribed down pressure adjustment on workpieces. The pneumatic system incorporates OSHA control circuitry and air logic which provides total operator safety through two-hand, anti-tie down operation of the pressure plates.
- In-process lap plate flatness control is provided for by three conditioning rings, which locate in yokes fitted with roller bearings. Workpieces are located within carriers or appropriate fixtures which run within the rings. Large parts of cylindrical shape can be substituted for the rings.
- The model 20 is ideally suited for lapping normal and high production quantities. In-shop lapping reduces costs of component processing and equipment maintenance programs. Worn parts are reconditioned and salvaged, thus eliminating scrap. Valve bodies, discs, gears, vanes, valve plates and shaft seals are a few of the components benefiting from the lapping process.
- The model 20 is equally at home in the laboratory, processing diverse materials such as semiconductors, electro-optics, optics and ceramics. This machine is also available in a open face version. See appropriate data sheet.

LAPMASTER®

MODEL 20

STANDARD FEATURES

- Heavy duty carbon steel weldment base.
- Wrap-around worktable. Facilitates parts handling.
- Three adjustable conditioning rings with roller yoke and bearing assemblies. Facilitates in-process plate flatness control.
- Abrasive feed system designed for water or oil based lapping slurries. This consists of a 1/15HP/0.05 kW pump, tank and three outlet system with individually variable flow control. This permits uniform lapping rates at each work station.
- High torque drive unit with 1.0 HP/0.75 kW motor and gear reducer.
- Standard Electrics: 110V 1ph 60 hz.
- OSHA control circuitry and air logic providing prescribed down pressure and total operator safety. (0-45 lbsf in-2/0-3.2 kgf cm-2 gauge pressure).
- Automatic digital cycle time. Time ranges: 00.1 to 999 Sec. 00.1 to 999 Min. 00.1 to 999 Hrs.

STANDARD TOOLING

- High density, cast iron radially serrated lap plate 20" O.D.x 5" I.D./508mm O.D.x 127mm I.D.
- Three high density, cast iron serrated conditioning rings 9" O.D.x 7 1/2" I.D./229mm O.D.x 191mm I.D.
- Three high density, cast iron pressure plates with lifting eyebolts 7 7/16" dia.x 1 1/2" thick/ 189mm dia.x 38mm thick. 20"/508mm hardened straight edge.
- Lap plate lifting tool.
- Three micarta workholder discs 7 7/16" dia.x 1/8" thick/189mm dia.x 3.2mm thick.
- Three felt pads 7 7/16" dia.x 1/2" thick/ 189mm dia.x 13mm thick.
- Starter sample of Lapmaster abrasive.
- Starter sample of Lapmaster vehicle.
- Operation and Maintenance Manual.
- Allen wrench.

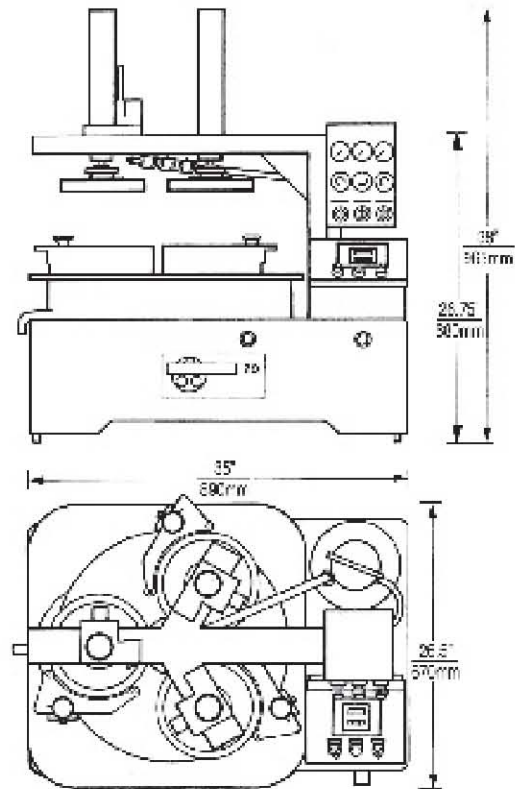

Weight: 2200 lbs
Shipping Weight: 1450 lbs

AVAILABLE OPTIONS

- Soft-start (to cushion start-up)
- Electronic variable speed drive (0-70 RPM).
- Non-standard voltages.
- Custom machines and tooling.
- Diamond Slurry dispensing systems.
- Various lapping/polishing plate materials.

Traditional Lapmaster quality combined with the model 20's performance capabilities insures processing excellence.



Lapmaster International
501 West Algonquin Road
Mount Prospect, IL 60056 U.S.A.
telephone 224.659.7101
fax 224.659.7103
toll free 877.FLATNESS
web www.lapmaster.com

Lapmaster has a policy of continued development and the specifications outlined above are subject to change without notice.